

Ecosystem and Nutrient Dynamics in the Seto Inland Sea, Japan

Naoki YOSHIE¹, Xinyu GUO¹, Naoki FUJII¹ and Tomohiro KOMORITA²

¹*Center for Marine Environmental Studies, Ehime University,
2-5, Bunkyo-cho, Matsuyama 790-8577, Japan*

²*Faculty of Environmental and Symbiotic Sciences, Prefectural University of Kumamoto,
3-1-100, Tsukide, Kumamoto 862-8502, Japan*

(Received 24 December 2010; accepted 12 January 2011)

Abstract—We studied the ecosystem and nutrient dynamics in the Seto Inland Sea from both field observations and numerical modeling. We investigated spatiotemporal variations in the group composition of phytoplankton and in the nutrient concentrations in Iyo-Nada, Hoyo Strait and Bungo Channel (parts of the Seto Inland Sea) with monthly field observations in 2009. From spring to early summer, nano- and pico-phytoplankton dominated in all three regions. From late summer to autumn, micro-phytoplankton (diatoms) bloomed in Iyo-Nada and Hoyo Strait, while a bloom was not observed in Bungo Channel. This autumn diatom bloom was probably caused by nutrient supply associated with a breakdown of the bottom cold water dome. For understanding the mechanism of the nutrient cycle and plankton dynamics, we developed a plankton functional types model eNEMURO (4 Nutrient, 4 Phytoplankton, 4 Zooplankton, 3 Detritus compartments), which was an extended version of NEMURO (a standard lower-trophic-level marine ecosystem model of PICES) by introducing the microbial food web and phosphorous cycle and dividing diatoms into two compartments according to temperature dependency. The model successfully reproduced the nutrient and phytoplankton dynamics observed in both Iyo-Nada and Bungo Channel.

Keywords: ecosystem dynamics and model, group composition of phytoplankton, Seto Inland Sea

INTRODUCTION

The Seto Inland Sea is a semi-enclosed coastal sea located in the western part of Japan. It is divided by about 600 small islands and peninsulas into several wide basins (called “Nada” in Japanese), and these basins are connected by narrow straits. This complex geometry creates various marine environments in the Seto Inland Sea. The efficiency of the primary production (nitrogen cycling rate) in the Seto Inland Sea is much higher than other enclosed seas (Seto Inland Sea: 4–5 yr⁻¹, Baltic Sea: 0.27 yr⁻¹, Mediterranean Sea: 0.18 yr⁻¹, North Sea: 1.5 yr⁻¹, Takeoka, 1997), and fish catch per unit area (21 t km⁻²yr⁻¹) in this sea is one of the world’s most productive (Hashimoto *et al.*, 1997). The Seto Inland Sea is also one of the most industrialized regions in Japan, and about 35 million people live

around this sea. The marine environment and ecosystem in the Seto Inland Sea has been significantly affected by anthropogenic impacts over the last 40 years (Takeoka, 2002). For sustainable fisheries and recovery of the marine environment and ecosystem, it is now more important than ever to carry out interdisciplinary and comprehensive research. In recent years, numerical simulations have been dramatically improved. A high resolution three dimensional physical ocean model for the Seto Inland Sea was developed by Chang *et al.* (2009), and the model successfully reproduced the physical field in the Seto Inland Sea. As the next step, development of a realistic marine ecosystem model for the Seto Inland Sea is expected. Development of the marine ecosystem model needs biogeochemical data in the Seto Inland Sea for the model validation. However there is only field data for some specific locations (Koizumi, 1999; Katano *et al.*, 2007; Hirose *et al.*, 2008), and no comprehensive data set is available in the western part of the Seto Inland Sea. In this study, we observed the spatiotemporal distribution of nutrients and phytoplankton in Iyo-Nada, Hoyo Strait, and Bungo Channel (western parts of the Seto Inland Sea) in 2009. We also developed a lower-trophic-level marine ecosystem model for the Seto Inland Sea for understanding the mechanism of the ecosystem and nutrient dynamics. We show the nutrient and phytoplankton dynamics and the preliminary results of our ecosystem model.

METHODS

Field observations were performed in the following three regions, Iyo-Nada with 7 stations, Hoyo Strait with 4 stations, and Bungo Channel with 16 stations (Fig. 1). We surveyed these regions 10 times from April to November in 2009. Water samples were collected onboard RV Isana using Niskin samplers on an Automatic Rosette sampler with a CTD system (JFE Advantech), and temperature, salinity, chlorophyll *a* (hereafter as Chl. *a*), and turbidity, were also measured by this CTD system. Nutrient samples were filtered with disposable filter unit (DISMIC-25cs 0.45 μm , Advantec), frozen in a deep freezer (-40°C), and measured in the onshore laboratory using a nutrient analyzer (Auto Analyzer III, Bran+Luebbe). Concentration of size-fractionated Chl. *a* was determined by the following procedures. Water samples (300 ml) were filtered onto three pore size filters (10 μm , 2 μm , and 0.2 μm , Whatman Nuclepore membrane filter) with cascaded 3 stage filter holder system (Sartorius) under low vacuum (<100 mm Hg). The filters were soaked in 5.0 ml DMF (*N,N*-dimethylformamide) and frozen in the deep-freezer (-40°C) until analysis. Concentration of Chl. *a* in the extract was measured by a fluorometer (TD-700, Turner Designs) with the method of Welschmeyer (1994). We regarded phytoplankton with cell size > 10 μm as micro-phytoplankton (mainly diatoms), with cell size 2–10 μm as nano-phytoplankton, and with cell size 0.2–2 μm as pico-phytoplankton.

We developed a lower-trophic-level marine ecosystem model eNEMURO (Fig. 2). eNEMURO including 4 nutrient compartments (NO_3 , NH_4 , $\text{Si}(\text{OH})_4$, PO_4), 4 phytoplankton compartments (2 types of micro-phyt., nano-phyt., pico-

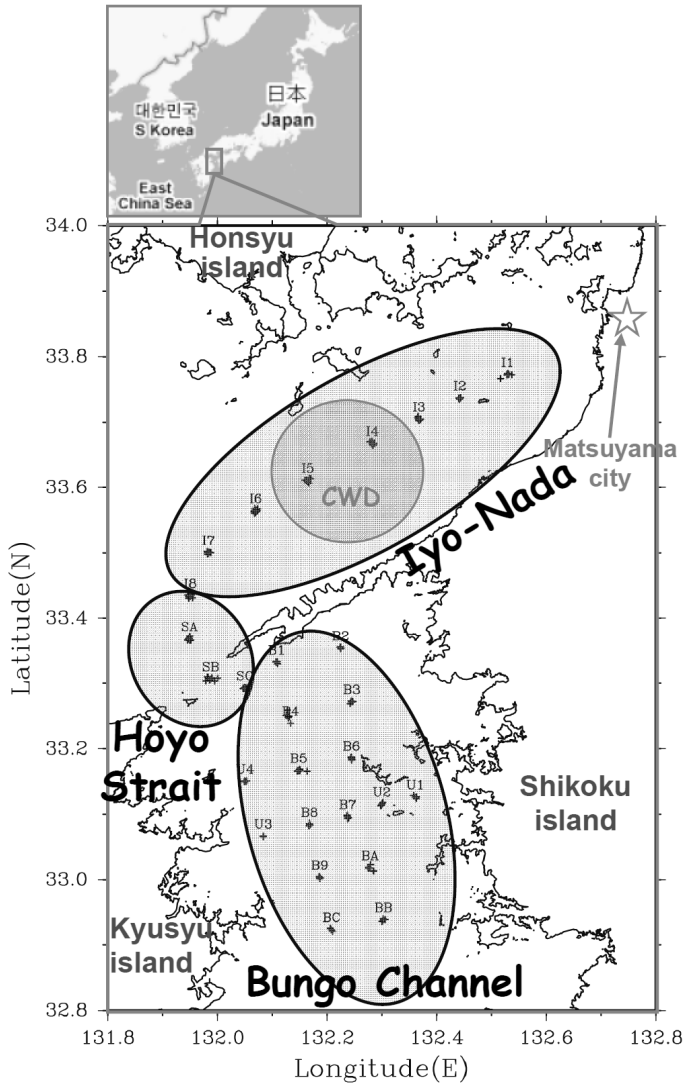

Fig. 1. Sampling locations in the western part of the Seto Inland Sea.

phyt.), 4 zooplankton compartments (macro-zoo, meso-zoo, micro-zoo, nano-zoo), 3 detritus compartments (POM, DOM, Opal). eNEMURO was an extended version of NEMURO (North Pacific Ecosystem Model for Understanding Regional Oceanography, Yoshie *et al.*, 2003, 2005, 2007; Yoshie and Yamanaka, 2005; Kishi *et al.*, 2007), which is a standard lower-trophic-level marine ecosystem model of PICES (North Pacific Marine Science Organization). We extended

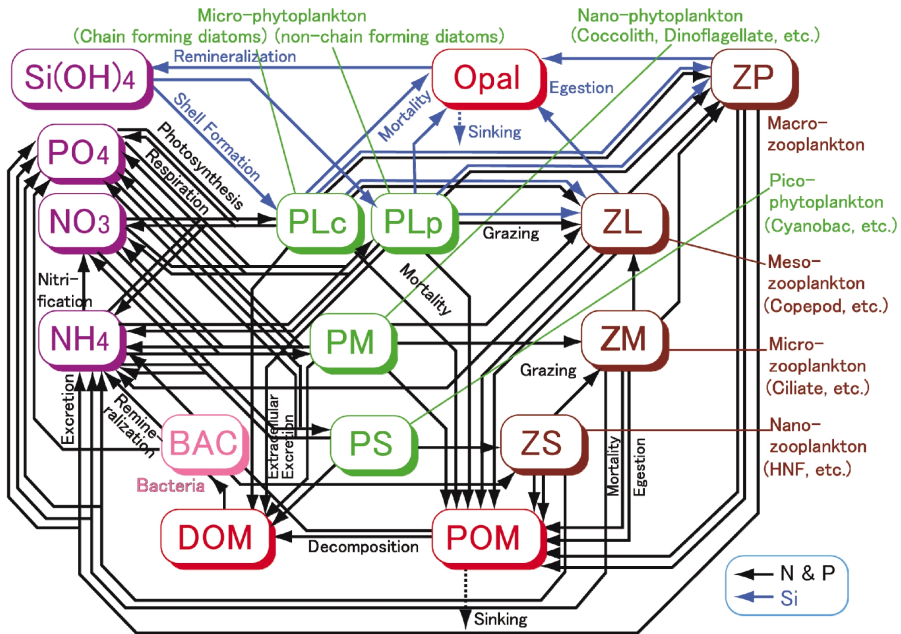

Fig. 2. Schematic view of the marine ecosystem model “eNEMURO”.

NEMURO by introducing the microbial food web and the phosphorous cycles and dividing micro-phytoplankton into two compartments according to temperature dependency. We simulated the ecosystem dynamics in Iyo-Nada and Bungo Channel using box type eNEMURO. For the driving force of the model, we used seasonal changes in the sea surface temperature, sea surface light condition, nutrient concentrations of bottom water, and nutrient concentrations in Hoyo Strait observed in 2009 as a horizontal boundary.

RESULTS AND DISCUSSION

Seasonal changes in the Iyo-Nada

From spring to early summer, concentration of nitrate was low at the surface, and concentration of Chl. *a* was also low with the dominance of small size phytoplankton groups such as pico- and nano-phytoplankton (Fig. 3). In summer, a bottom cold water dome (hereafter, CWD) formed and concentrations of nitrate and silicic acid in the CWD were remarkably high compared with those in the surface water. From the early summer, concentration of Chl. *a* over the CWD increased associated with the dominance of large size phytoplankton such as diatoms, and the fraction of diatoms in the CWD was also high. From late summer to autumn, a noticeable diatom bloom occurred with the collapse of the CWD, and concentrations of silicic acid and nitrate at the surface were depleted by the

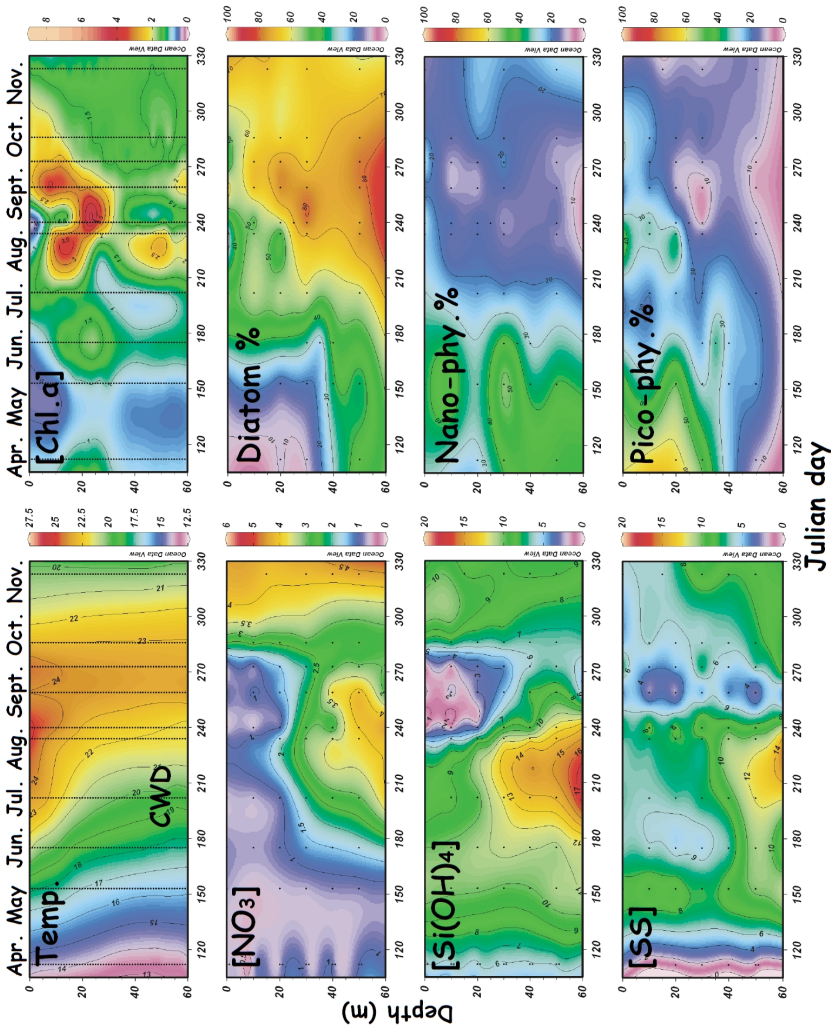

Fig. 3. Seasonal changes of nutrient and phytoplankton in Iyo-Nada. Temp. is water temperature (°C). [NO₃] and [Si(OH)₄] are concentrations of nitrate and silicic acid (μM). [SS] is concentration of suspended solids (FTU). [Chl. *a*] is the concentration of chlorophyll *a* (μg l⁻¹). Diatom%, Nano-phyt.%, and Pico-phyt.% are fractions of each size group in the phytoplankton assemblage (%). CWD is the bottom cold water dome.

diatom bloom. After autumn, concentration of Chl. *a* was kept relatively high value with the dominance of diatoms. Seasonal change in the silicic acid was significantly different from that in the nitrate, while it was similar to that in suspended solids (hereafter, SS). The source of silicic acid might be related with terrigenous suspended matter supplied by rivers in the central and eastern parts of the Seto Inland Sea.

Seasonal changes in Hoyo Strait

The sea water in Hoyo Strait was vertically well mixed by tidal mixing throughout the year (Fig. 4). From spring to early summer, concentrations of nitrate and Chl. *a* were low, and nano- and pico-phytoplankton were dominant in the phytoplankton assemblage. From the early summer, concentration of Chl. *a* and fraction of diatoms increased with the increase in nitrate. From late summer to autumn, diatoms bloomed with the rapid decrease of silicic acid. Seasonal changes of phytoplankton in Hoyo Strait after autumn were different from those in Iyo-Nada. Although nutrient concentrations increased after autumn, concentration of Chl. *a* and the fraction of diatoms quickly decreased, because light conditions for diatoms might degenerate with the decrease in the solar radiation and deep tidal mixing. Seasonal change in the silicic acid in Hoyo Strait was different from that for nitrate as in Iyo-Nada, however it was also different from that in the SS.

Seasonal changes in Bungo Channel

The ecosystem changes in Bungo Channel before early summer were similar to the other two regions, however a remarkable diatom bloom did not occur in this region (Fig. 5). Though the fraction of diatoms increased after early summer, the other small phytoplankton groups also maintained a relatively high fraction in the phytoplankton assemblage. This is because the concentration of silicic acid in Bungo Channel was lower than values in the other two regions, and growth of diatoms in Bungo Channel was limited by insufficient silicic acid. After autumn, the concentration of Chl. *a* remained at a relatively high value, and the 3 groups of phytoplankton coexisted with each other.

Model simulation in Iyo-Nada and Bungo Channel

Our ecosystem model successfully reproduced the nutrient and phytoplankton dynamics in both Iyo-Nada and Bungo Channel (Figs. 6 and 7). The timing of change and variation ranges of nutrients were similar to those observed in 2009. The different seasonal changes between silicic acid and the other two nutrients were also well reproduced. Seasonal changes not only in the total phytoplankton but also in the 3 groups of phytoplankton were also well reproduced in both regions. Fractions of diatoms simulated in Bungo Channel were lower than those in Iyo-Nada. Analysis of the nutrient limitation terms in the model showed that diatoms in Bungo Channel were under relatively severe stress by insufficient silicic acid compared with silicic acid concentrations in Iyo-Nada.

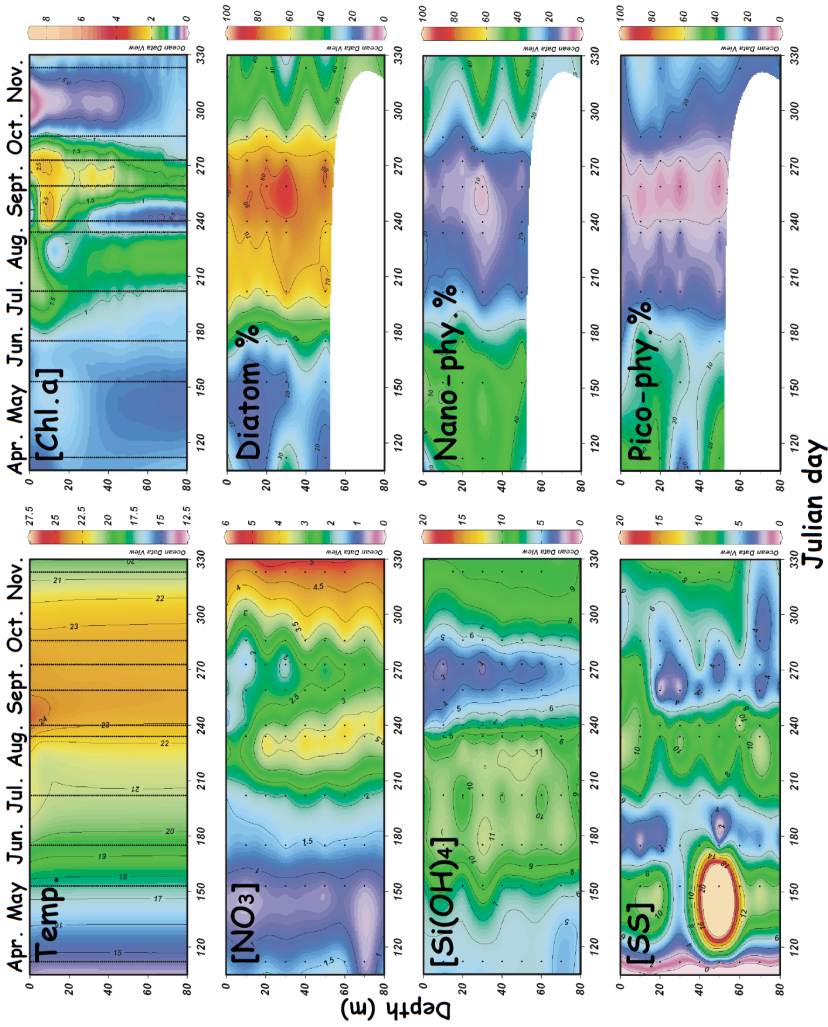

Fig. 4. Seasonal changes of nutrient and phytoplankton in Hoyo Strait. Temp. is water temperature ($^{\circ}\text{C}$). [NO₃] and [Si(OH)₄] are concentrations of nitrate and silicic acid (μM). [SS] is concentration of suspended solid (FTU). [Chl. *a*] is the concentration of chlorophyll *a* ($\mu\text{g l}^{-1}$). Diatom %, Nano-phyt. %, and Pico-phyt. % are fractions of each size group in the phytoplankton assemblage (%).

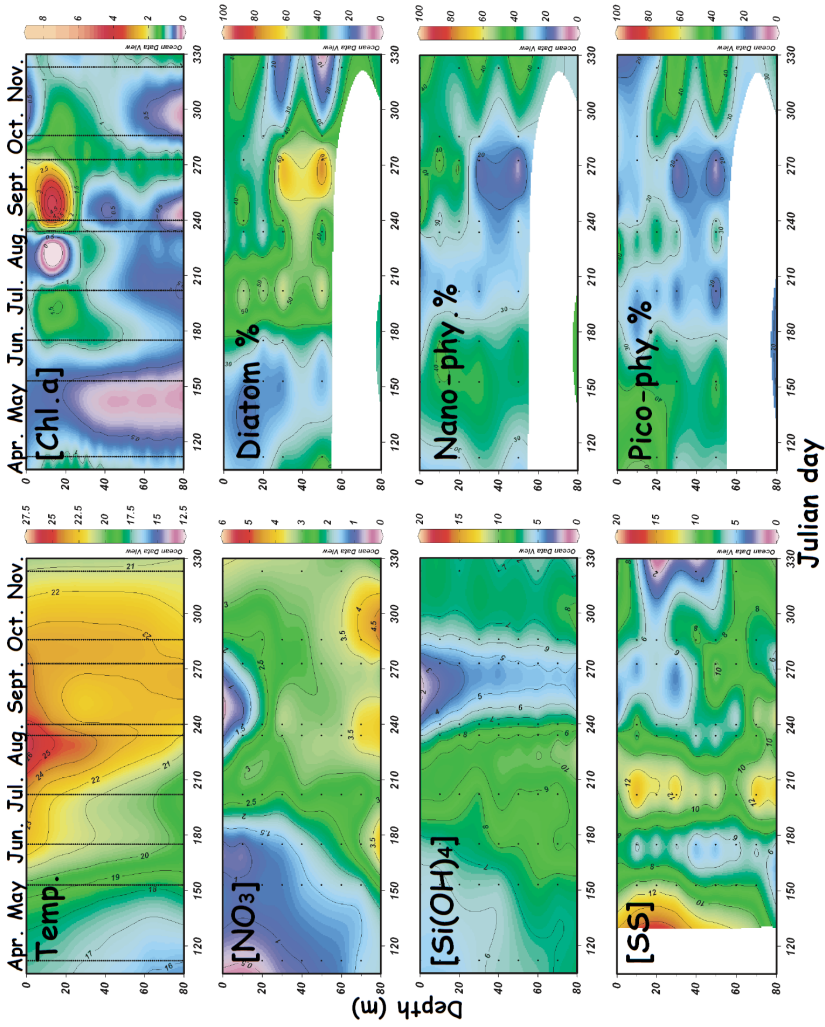

Fig. 5. Seasonal changes of nutrient and phytoplankton in Bungo Channel. Temp. is water temperature (°C), [NO₃] and [Si(OH)₄] are concentrations of nitrate and silicic acid (µM), [SS] is concentration of suspended solid (FTU), [Chl. a] is the concentration of chlorophyll a (µg l⁻¹), Diatom %, Nano-phyt. %, and Pico-phyt. % are fractions of each size group in the phytoplankton assemblage (%).

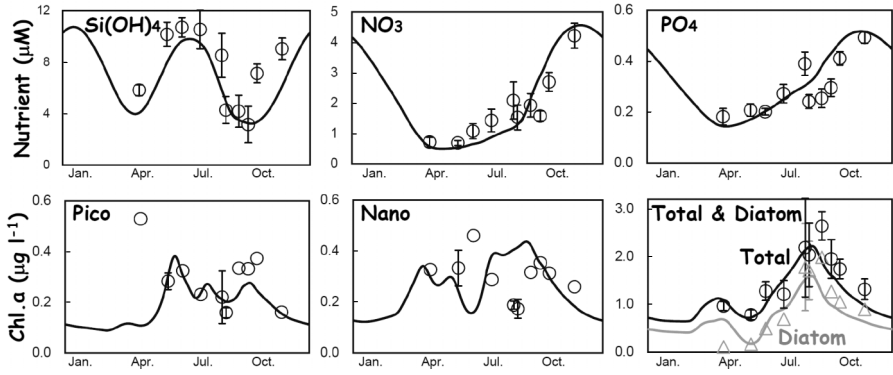

Fig. 6. Seasonal changes of nutrient and phytoplankton in Iyo-Nada simulated by eNEMURO and observed in 2009. Upper figures show the concentrations of silicic acid, nitrate, and phosphate (μM). Lower figures show the concentrations of chlorophyll *a* of pico-, nano-, micro- (diatoms), and total-phytoplankton. Lines are model results. Circles and triangles are observed data averaged from 0 to 40 m depth.

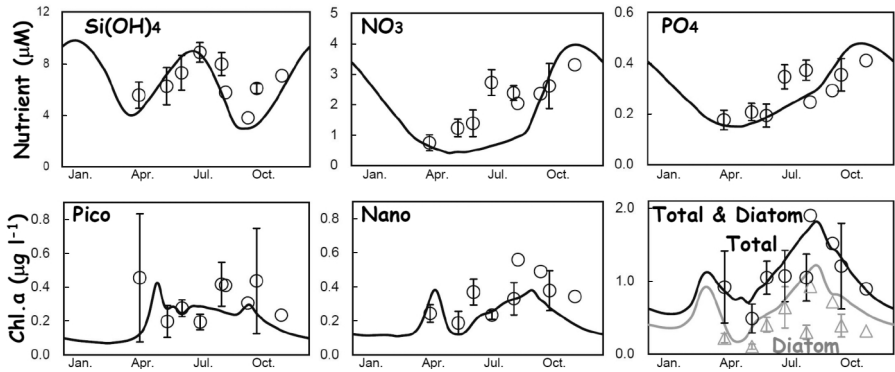

Fig. 7. Seasonal changes of nutrient and phytoplankton in Bungo Channel simulated by eNEMURO and observed in 2009. Upper figures show the concentrations of silicic acid, nitrate, and phosphate (μM). Lower figures show the concentrations of chlorophyll *a* of pico-, nano-, micro- (diatoms), and total-phytoplankton. Lines are model results. Circles and triangles are observed data averaged from 0 to 40 m depth.

CONCLUSION

We clarified spatiotemporal distribution of nutrient and phytoplankton in the western Seto Inland Sea, Japan by monthly field observations. Between spring and early summer, nano- and pico-phytoplankton were dominant under low nutrient conditions. In late summer, typical diatom blooms occurred with the collapse of the bottom cold water dome in Iyo-Nada. On the other hand, a

remarkable diatom bloom was not observed in Bungo Channel due to the low concentration of silicic acid. After autumn, diatoms maintained a relatively high biomass in Iyo-Nada, while the three size groups of phytoplankton coexisted in Bungo Channel. Using a lower-trophic-level marine ecosystem model, we successfully reproduced the characteristic ecosystem dynamics in both Iyo-Nada and Bungo Channel. The mechanism of the low diatom fraction in Bungo Channel (i.e., insufficient silicic acid) was confirmed by the model.

Acknowledgments—We thank H. Onishi as the captain of the RV “Isana” and the participants in the field observations. The study was supported by a grant-in-aid for the Global COE Program funded by Ministry of Education, Culture, Sports, and Technology of Japan (MEXT) and Japan Society for the Promotion of Science (JSPS), and JSPS KAKENHI (21310012).

REFERENCES

- Chang, P. H., X. Guo and H. Takeoka (2009): A numerical study of the seasonal circulation in the Seto Inland Sea, Japan. *J. Oceanogr.*, **65**, 721–736.
- Hashimoto, H., T. Hashimoto, O. Matsuda, K. Tada, K. Tamai, S. Uye and T. Yamamoto (1997): Biological productivity of lower trophic levels of the Seto Inland Sea. p. 17–58. In *Sustainable Development in the Seto Inland Sea, Japan—From the Viewpoint of Fisheries—*, ed. By T. Okaichi and T. Yanagi, Terra Scientific Publishing Company, Tokyo.
- Hirose, M., T. Katano, Y. Hayami, A. Kaneda, T. Kohama, H. Takeoka and S. Nakano (2008): Changes in the abundance and composition of picophytoplankton in relation to the occurrence of a Kyucho and a bottom intrusion in the Bungo Channel, Japan. *Estur. Coast. Shelf Sci.*, **76**, 293–303.
- Katano, T., A. Kaneda, N. Kanzaki, Y. Obayashi, A. Morimoto, G. Onitsuka, H. Yasuda, S. Mizutani, Y. Kon, K. Hata, H. Takeoka and S. Nakano (2007): Distribution of prokaryotic picophytoplankton from Seto Inland Sea to Kuroshio region with special reference to Kyucho enumerated with a dual laser flow cytometer and a spectrofluorometer. *Aquat. Microbiol. Ecol.*, **46**, 191–201.
- Kishi, M. J., D. V. Eslinger, M. Kashiwai, B. A. Megrey, D. M. Ware, F. E. Werner, M. Noguchi-Aita, T. Azumaya, M. Fujii, S. Hashimoto, H. Iizumi, Y. Ishida, S. Kang, G. A. Kantakov, H. Kim, K. Komatsu, V. V. Navrotsky, L. S. Smith, K. Tadokoro, A. Tsuda, O. Yamamura, Y. Yamanaka, K. Yokouchi, N. Yoshie, J. Z. Zhang, Y. I. Zuenko and V. I. Zvalinsky (2007): NEMURO—a lower trophic level model for the North Pacific marine ecosystem. *Ecol. Modelling*, **202**(1–2), 12–25.
- Koizumi, Y. (1999): Kyucho events and the mechanism of phytoplankton growth in the eastern coast of the Bungo Channel. Doctoral Thesis, The University of Tokyo, 145 pp. (in Japanese).
- Takeoka, H. (1997): Comparison of the Seto Inland Sea with other enclosed seas from around the world. p. 223–247. In *Sustainable Development in the Seto Inland Sea, Japan—From the Viewpoint of Fisheries—*, ed. By T. Okaichi and T. Yanagi, Terra Scientific Publishing Company, Tokyo.
- Takeoka, H. (2002): Progress in Seto Inland Sea research. *J. Oceanogr.*, **58**, 93–107.
- Welschmeyer, N. A. (1994): Fluorometric analysis of chlorophyll *a* in the presence of chlorophyll *b* and pheopigments. *Limnol. Oceanogr.*, **39**, 1985–1992.
- Yoshie, N. and Y. Yamanaka (2005): Processes causing the temporal changes in Si/N ratios of nutrient consumptions and export flux during the spring diatom bloom. *J. Oceanogr.*, **61**, 1059–1073.
- Yoshie, N., Y. Yamanaka, M. J. Kishi and H. Saito (2003): One dimensional ecosystem model simulation of the effects of vertical dilution by the winter mixing on the spring diatom bloom. *J. Oceanogr.*, **59**, 563–571.

- Yoshie, N., M. Fujii and Y. Yamanaka (2005): Ecosystem changes after the SEEDS iron fertilization in the western North Pacific simulated by a one-dimensional ecosystem model. *Prog. Oceanogr.*, **64**, 283–306.
- Yoshie, N., Y. Yamanaka, K. A. Rose, D. L. Eslinger, D. M. Ware and M. J. Kishi (2007): Parameter sensitivity study of the NEMURO lower trophic level marine ecosystem model. *Ecol. Modelling*, **202**, 26–37.

N. Yoshie (e-mail: nyoshie@sci.ehime-u.ac.jp)